



**TMA**  
**SERIES**

***User's Manual***

**STEREO POWER AMPLIFIER**  
**TMA500-2/1000-2**

---



**TOPP PRO MUSIC GEAR**  
[www.topppro.com](http://www.topppro.com)

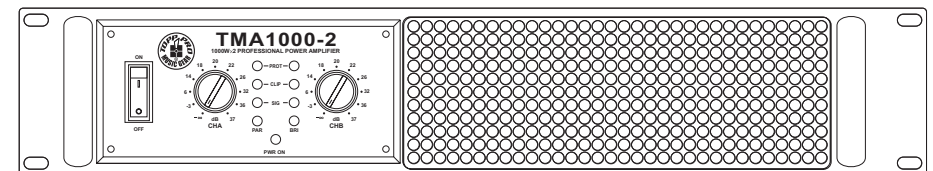

**RTA**  
**SERIES**

## Safety Related Symbols



This symbol, wherever used, alerts you to the presence of un-insulated and dangerous voltages within the product enclosure. These are voltages that may be sufficient to constitute the risk of electric shock or death.



This symbol, wherever used, alerts you to important operating and maintenance instructions.



Please read.



Protective Ground Terminal



AC mains (Alternating Current)



ON: Denotes the product is turned on.

OFF: Denotes the product is turned off.

### WARNING

Describes precautions that should be observed to prevent the possibility of death or injury to the user.



### CAUTION

Describes precautions that should be observed to prevent damage to the product.

Disposing of this product should not be placed in municipal waste but rather in a separate collection.

### WARNING

#### Power Supply

Ensure that them a inssource voltage (AC outlet) matches the voltage rating of the product. Failure to do so could result in damage to the product and possibly the user. Unplug the product before electrical storms occur and when unused for long periods of time to reduce the risk of electric shock or fire.

#### External Connection

Always use proper ready-made insulated mains cabling (power cord). Failure to do so could result in shock/death or fire. If in doubt, seek advice from a registered electrician.

#### Do Not Remove Any Covers

Within the product are areas where high voltages may present. To reduce the risk of electric shock do not remove any covers unless the AC mains power cord is removed. Covers should be removed by qualified service personnel only.

No user serviceable parts inside.

#### Fuse

To prevent fire and damage to the product, use only the recommended fuse type as indicated in this manual. Do not short-circuit the fuse holder. Before replacing the fuse, make sure that the product is OFF and disconnected from the AC outlet.

#### Protective Ground

Before turning the unit ON, make sure that it is connected to Ground. This is to prevent the risk of electric shock.

Never cut internal or external Ground wires. Like wise, never remove Ground wiring from the Protective Ground Terminal.

#### Operating Conditions

Always install in accordance with the manufacturer's instructions.

To avoid the risk of electric shock and damage, do not subject this product to any liquid/rain or moisture.

Do not use this product when in close proximity to water.

Do not install this product near any direct heat source. Do not block areas of ventilation. Failure to do so could result in fire.

Keep product away from naked flames.

#### IMPORTANT SAFETY INSTRUCTIONS

Read these instructions

Follow all instructions

Keep these instructions. Do not discard.

Heed all warnings.

Only use attachments/ accessories specified by the manufacturer.

#### Power Cord and Plug

Do not tamper with the power cord or plug. These are designed for your safety.

Do not remove Ground connections!

If the plug does not fit your AC out let seek advice from a qualified electrician.

Protect the power cord and plug from any physical stress to avoid risk of electric shock.

Do not place heavy objects on the power cord. This could cause electric shock or fire.

#### Cleaning

When required, either blow off dust from the product or use a dry cloth.

Do not use any solvents such as Benzol or Alcohol.

For safety, keep product clean and free from dust.

#### Servicing

Refer all servicing to qualified service personnel only. Do not perform any servicing other than those instructions contained within the User's Manual.

The mains plug or an appliance coupler is used as the disconnect device, the disconnect device shall remain readily operable.

#### PORTABLE CART WARNING



Carts and stands - The component should be used only with a cart or stand that is recommended by the manufacturer. A component and cart combination should be moved with care. Quick stops, excessive force, and uneven surfaces may cause the component and cart combination to overturn.

## GUARANTEE

8

**Topp Pro** guarantees the normal operation of the product against any defect of manufacture and/ or vice of material, by the term of (12) months, counted as of the date of purchase on the part of the user, committing itself to repair or to change, to its election, without position some, any piece or component that will fail in normal conditions of use within the mentioned period.

This guarantee is valid if the original buyer will have to present/display this certificate properly sealed and signed by the selling house, accompanied by the corresponding invoice of purchase where it consisted the model and serial number of the acquired equipment.

The guarantee does not cover:

- Damages caused by the illegal use of the product, repair and/or nonauthorized modification conducted by people by **Topp Pro**.
- Damages caused by the connection of the equipment to other equipment different from the specified ones in the manual of use, or by bad connection to these last ones.
- Damages caused by electrical storms, blows and/or incorrect transport.
- Damages caused by excesses or falls of tension in the network or by connection to networks with a tension different from the required one by the unit.
- Damages caused by the presence of sand, acid of batteries, water, or any strange element inside the equipment.
- Deteriorations produced by the course of the time, use and/or normal wear of the unit.
- Alteration or absence of the serial number of factory of the equipment.

The repairs could only be carried out the authorized technical service by **Topp Pro**, that will inform about the term and other details into the repairs to take place according to this guarantee.

**Topp Pro**, will repair this unit in counted a term nongreater to 30 days as of the date of entrance of the unit to the Technical Service. In those cases in that due to the particularity of the spare part, outside necessary their import, the repair time and the viability of the same one will be subject to the effective norms for the import of parts, in which case one will inquire to the user about the term and possibility into repair.

With the object of its correct operation, and of the validity of this one guarantee, this product will have to be installed and to be used according to the instructions that are detailed in the manual associate or the package of the product.

This unit will be able to appear for its repair, next to the invoice of purchase (or any other proof where the date of purchase consists), to its authorized distributor **Topp Pro** or an authorized technical center on watch by **Topp Pro**.

#### Exclusion of damages:

**THE RESPONSABILITY OF TOPP PRO BY ANY DEFECTIVE PRODUCT IS LIMITED THE REPAIR OR THE REPLACEMENT OF HE HIMSELF, TO TOPP OPTION PRO. IF WE CHOSE TO REPLACE THE PRODUCT, THE REPLACEMENT CAN BE A RECONDITIONATED UNIT. TOPP PRO WILL NOT BE RESPONSIBLE BY THE DAMAGES BASED ON THE LOST, INCONVENIENCE, LOSS OF USE, BENEFITS, LOST SAVINGS, BY THE DAMAGE TO OTHER EQUIPMENT OR OTHER ARTICLES IN THE USE SITE, OR BY ANY OTHER DAMAGE IF HE IS FORTUITOUS, CONSEQUENT OR OF ANOTHER TYPE, ALTHOUGH TOPP PRO HAS BEEN NOTICED OF THE POSSIBILITY OF SUCH DAMAGES.**

Some states do not allow to the exclusion or the limitation to the fortuitous or consequent damages, so the aforesaid limitation can not be applied to you.

This guarantee gives specific legal rights him, you can also have other right that varies of state to state.

General Specifications	
Protections	Full short circuit, open circuit, thermal, ultrasonic, and RF protection stable into reactive or mismatched loads, turn ON/OFF, muting, tried crowbar.
Controls	Front: AC switch(soft-start), Input level control for each channel Rear: stereo/ parallel/ bridged selector, limit ON/OFF selector
Indicators	SIGNAL: 2 green LED      CLIP: 2 red LED      POWER: 1 Blue LED PROTECTION: 2 red LED      BRIDGE: 1 Yellow LED      PARALLEL: 1 Yellow LED
Connectors	INPUT : Active balanced XLR or TRS JACK OUTPUT: "Touch-proof" binding posts and speak-on jacks
Power Supply	Available for 80-135V or 160~270V AC 50/60 Hz
Dimensions(mm)	483(W)*460(D)*88.8(H)
Weight	9kg(TMA500-2)                      11kg(TMA1000-2)

**INDEX**

---

1. INTRODUCTION.....	4
2. FEATURES .....	4
3. CONTROL ELEMENTS .....	5
4. REAR PANEL .....	6
5. WIRING CONNECTIONS .....	14
6. BLOCK DIAGRAM .....	16
7. TECHNICAL SPECIFICATINS .....	17
8. GUARANTEE .....	19

Don't forget to visit our website at [www.topppro.com](http://www.topppro.com) for more information about this and other Topp Pro products.

## 1 INTRODUCTION

The TMA500-2/1000-2 switching power professional Amplifier is designed for professional use on stage.

The high-quality components and the carefully designed circuits ensure excellent audio performance and an extremely linear frequency response. In fact, the switching power technology offers, together with an increased efficiency and a better control of heat dissipation than conventional power supply systems, a drastic reduction of dimensions and weight, for easier transportation and installation. This Amplifier guarantees reliability and in the most demanding conditions.

We believe the TMA500-2/1000-2 will provide a perfect performance, what you get is unprecedented performance at an incredibly attractive price.

## 2 Features

- High current switching power allowing high power output with low noise and low distortion
- Substantial protection circuitry like thermal, short circuit, output DC offset, power on/off muting and Therefore protection
- Built-in limiter
- Balanced XLR-TRS combo input jack
- Binding post and Speakon output connectors
- front mounted gain controls for easy access
- Signal, Clip protect, Parallel mode, Bridge mode, and Power LED indicators to monitor performance.

## TECHNICAL SPECIFICATIONS

Power Specifications(tolerance +/-5%)		TMA500-2	TMA1000-2
Stereo Mode (Both Channels Drive)	2 ohms(EIAJ)	750W*2	1500W*2
	4 ohms(RMS)	500W*2	1000W*2
	8 ohms(RMS)	300W*2	600W*2
Bridge Mono Mode	8 ohms(RMS)	1000W	2000W
	4 ohms(EIAJ)	1500W	3000W
Electrical Specification			
Input Sensitivity (Limit Off)		0.9-1.1V(0+/-1dBv)	0.9-1.1V(0+/-1dBv)
Input Impedance		20k ohms balanced or 10k Ohms unbalanced	
Frequency Response (at 10dB Rated Output Power)		20Hz ~ 20KHz(+0/-1dB)	
Voltage Gain		33+/-0.5dB	37+/-0.5dB
THD+N (Ref. 1K 1/8 Rated Power, A-Weighted)		<0.1%	<0.1%
S/N rate (Ref. Rated Power, A-Weighted)		>100dB	>100dB
Crosstalk (Below Rated Power)		>70dB	>70dB
Damping Factor(1K 8 ohms)		>500	>500
Power/Output Circuitry		Switching Power Class AB	Switching Power Class 2H

# 6 BLOCK DIAGRAM

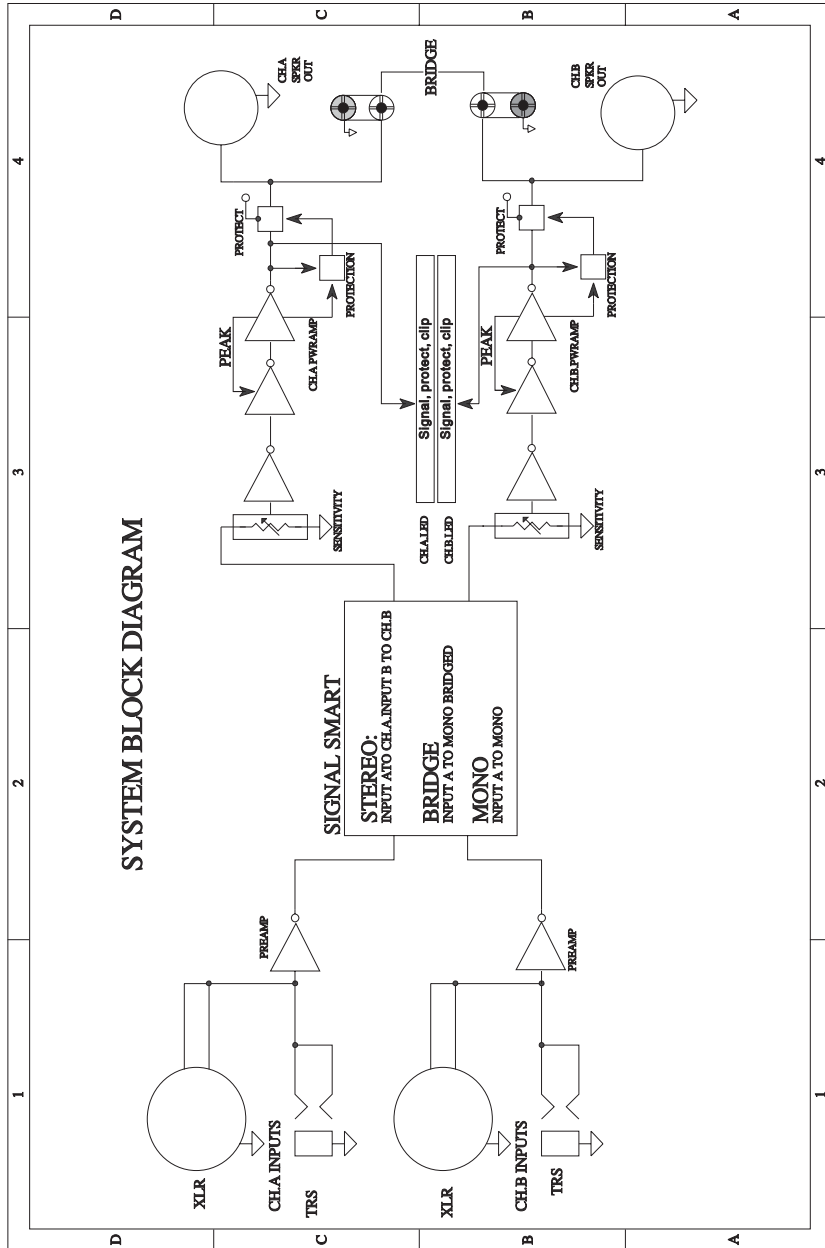

# CONTROL ELEMENTS

# 3

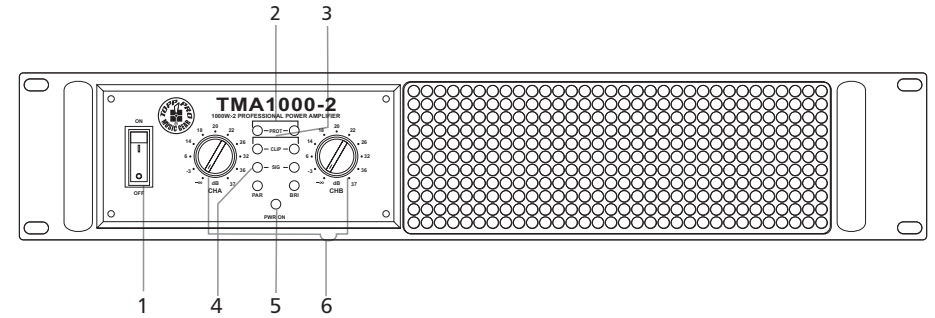

### 1- POWER SWITCH

It switches the amplifier ON and OFF.

### 2- OPERATION AND PROTECTION LED

When there presents signal, the red LED lights up. When at protection status, the LED turns off.

### 3- CLIP LED

This red LED lights up when the input signal is too strong. Please to reduce input level until clip LED turning off.

### 4- SIGNAL LED

These green LEDs light up when the respective channel's output signal pass through.

### 5-POWER LED

It lights up when the amplifier is powered on.

### 6-LEVEL CONTROL (For CH 1 & CH 2)

Adjust the output signal level to avoid signal distortion.

# 4 REAR PANEL

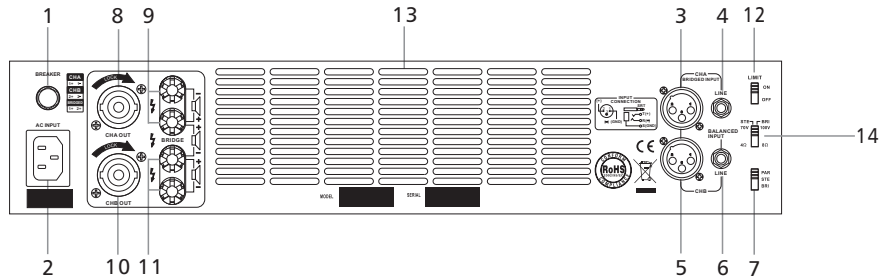

### 1- Breaker

This switch works as fuse for protecting the unit from damage. When the unit is overloaded or the temperature inside the unit is too high, this pushing-button will spring up and break the power supply. The power supply will be restored with pushing this switch down again.

### 2- AC Input

Use it to connect your TMA 500-2/TMA 1000-2 to the supplied AC cord.

### 3- Channel A XLR Input

This XLR jack will accept any balanced or unbalanced low impedance line level source by means of a three-pin XLR plug. The wiring for the plug is as follows: Pin1=Ground, Pin2=Signal+, Pin3=Signal-.

### 3- Channel A TRS Input

This TRS(1/4") jack will accept line level signal sources by means of cables fit with standard 1/4" phone plugs. This input are compatible with balanced and unbalanced low impedance, and high impedance sources. Low impedance balanced input is to be wired as follows: Tip=signal+, Ring= signal-, Sleeve=Ground.

Note: in the mono mode, Channel A input jacks are used and Channel B input jacks.

### 4-Channel B XLR Input

This XLR jack will accept any balanced or unbalanced low impedance line level source by means of a three-pin XLR plug.

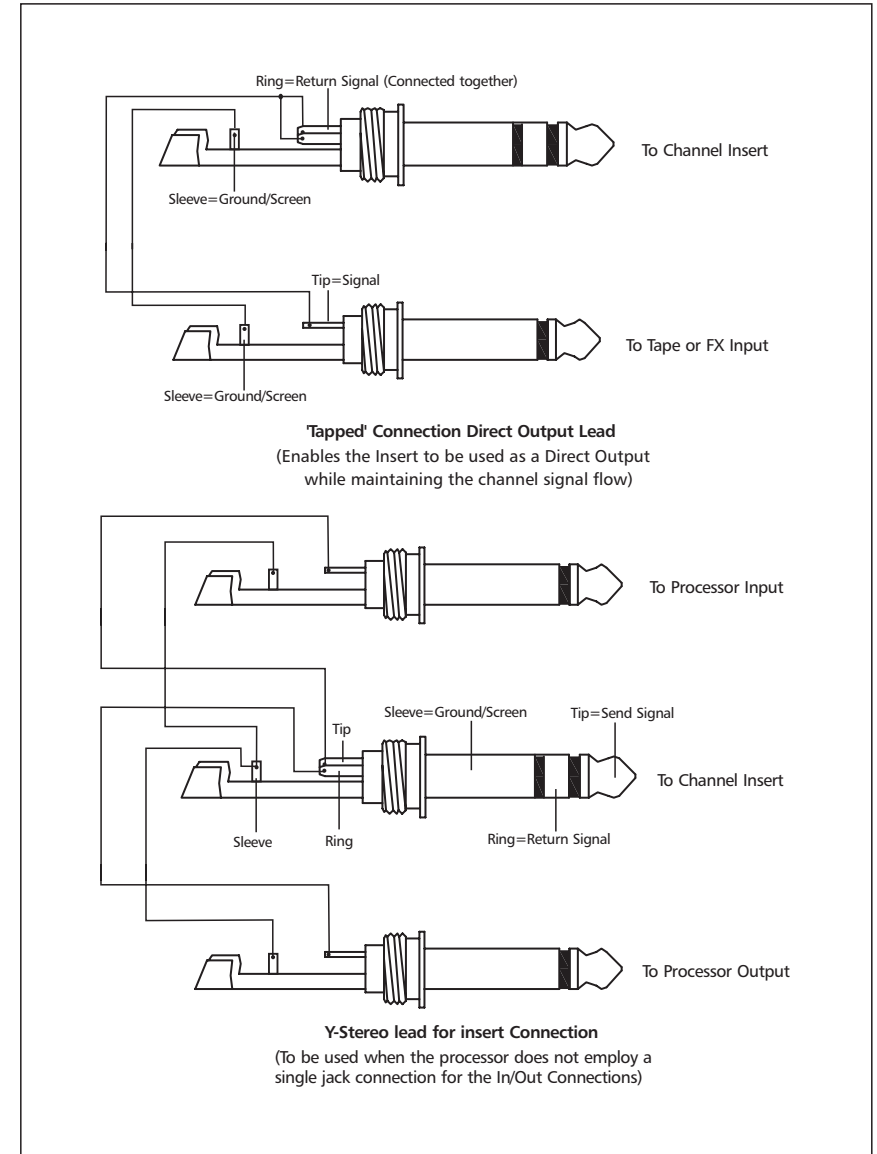

# 5 WIRING CONNECTIONS

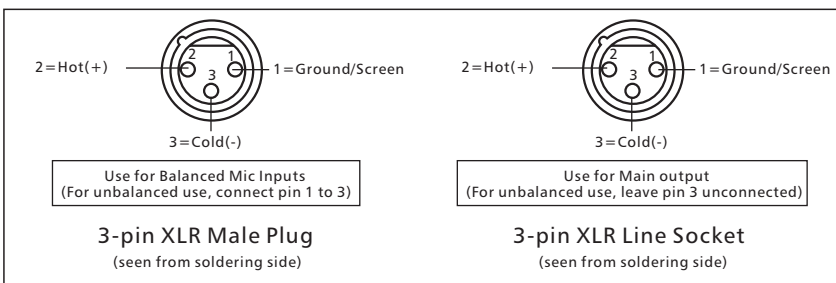
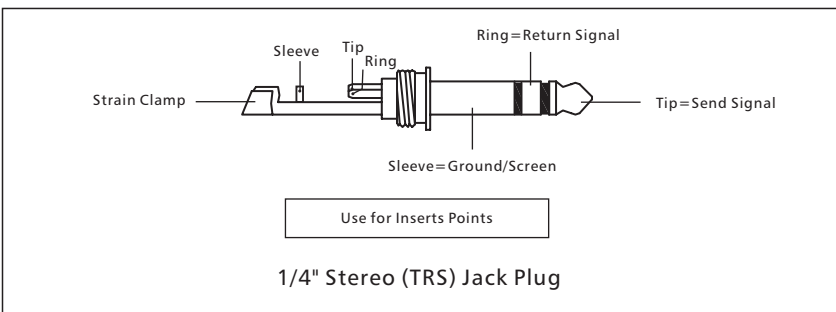
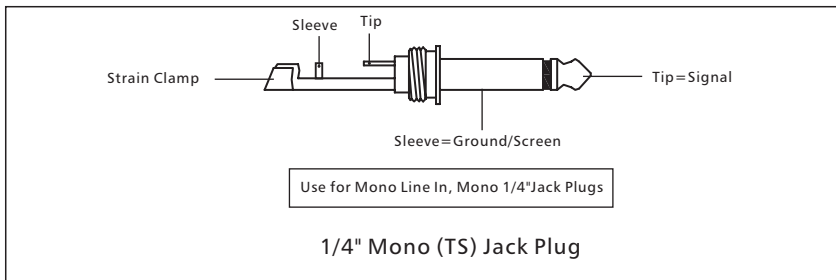
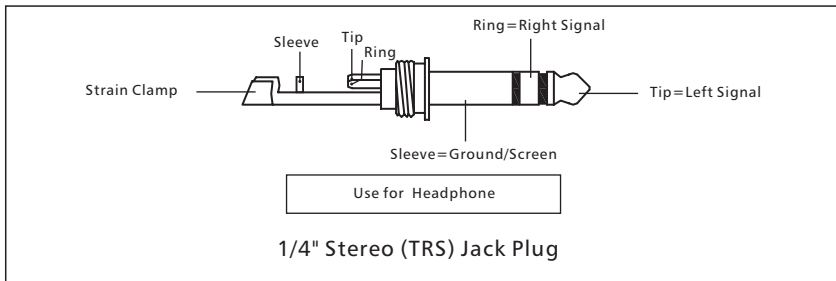

## 6- Channel B TRS Input

This TRS(1/4") jack will accept line level signal sources by means of cables fit with standard 1/4" phone plug.

## 7- Signal Smart Switch

Use this switch to select the operating mode of the amplifier. The switch functions as follows:

STEREO: input A to CH A amp, input B to CH B amp; BRIDGE: input A to Mono Bridge amps;

PARALLEL: input from channel A/B, both CHA and CHB will output signal.

## 8- Channel A Speakon NL-4R

Connect the amplifier to your speakers using these speakon jacks.

## 9- Channel A Binding Post

Connect the amplifier to your speakers using these jacks. The five way binding posts for channel A are wired in parallel. When using the amplifier in Bridge or Parallel mode, use the RED terminals of the binding post sets after the input selector switch(#7) to BRIDGE position.

## 10- Channel B Speakon NL-4R

Connect the amplifier to your speakers using these speakon jacks.

## 11- Channel B Binding Post

Connect the amplifier to your speakers using these jacks. The five way binding posts for channel A are wired in parallel. When using the amplifier in Bridge or Parallel mode, use the RED terminals of the binding post sets after the input selector switch(#7) to BRIDGE position.

## 12- Limit Switch

Control the built-in limiter on/off.

## 13- Exhaust Vents

Air is drawn from front grilles, flown through the unit and heat sink, and then exhausted via the rear vents. Do not block or impede the air flow through these vents and keep the vent areas free of foreign materials.

## 14- 4Ω/8Ω & 70V/100V mode Switch

Use this switch to select the 4Ω/8Ω & 70V/100V mode of the amplifier.

# 4 APPLICATIONS

## Stereo Operation

TMA500-2/1000-2 can be used in the stereo mode as two separate 1000/2000 watt units, each capable of driving loads down to 4 ohms. Each channel operates independently and has its own input connectors, sensitivity level controls, signal indicator LEDs, automatic limiter, fault protection circuitry, power amp, and speaker outputs. In the stereo mode, the signal smart switch must be set to the stereo position. One application of the stereo mode uses one channel of the amplifier for the left house speakers and the other channel for the right. The mixing board channels can be panned left or right according to the position of the instruments on the stage. This approach provides a more accurate reproduction of the live performance.

SWITCH SET TO STEREO

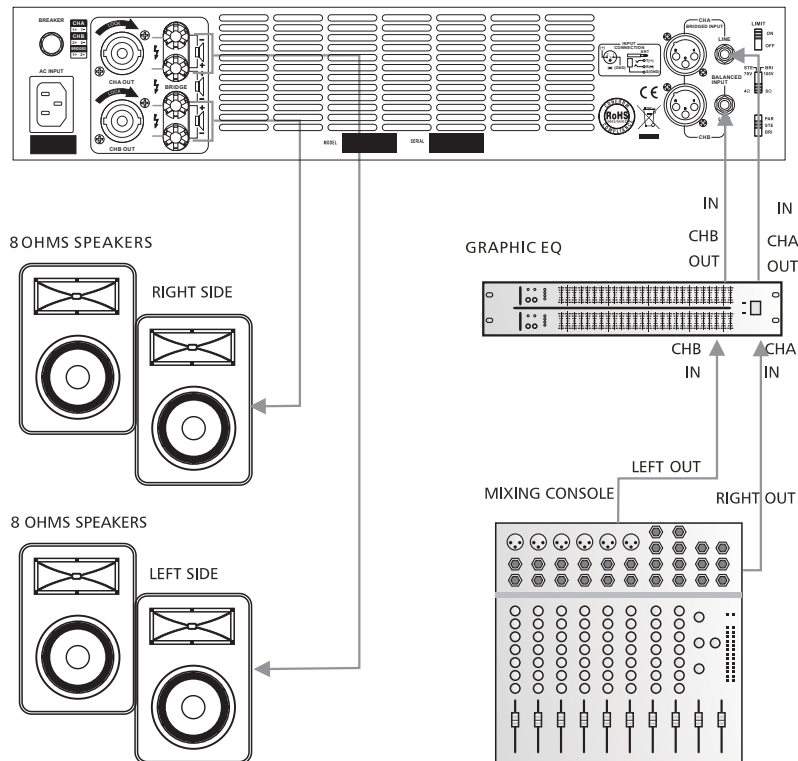

## Patching two bridge mono mode system

Two bridge mono amplifiers can be patched together (operated in mono mode) by connecting signal cable between their input jacks. The signal smart switch must be set to the bridge position.

SWITCH SET TO BRIDGE

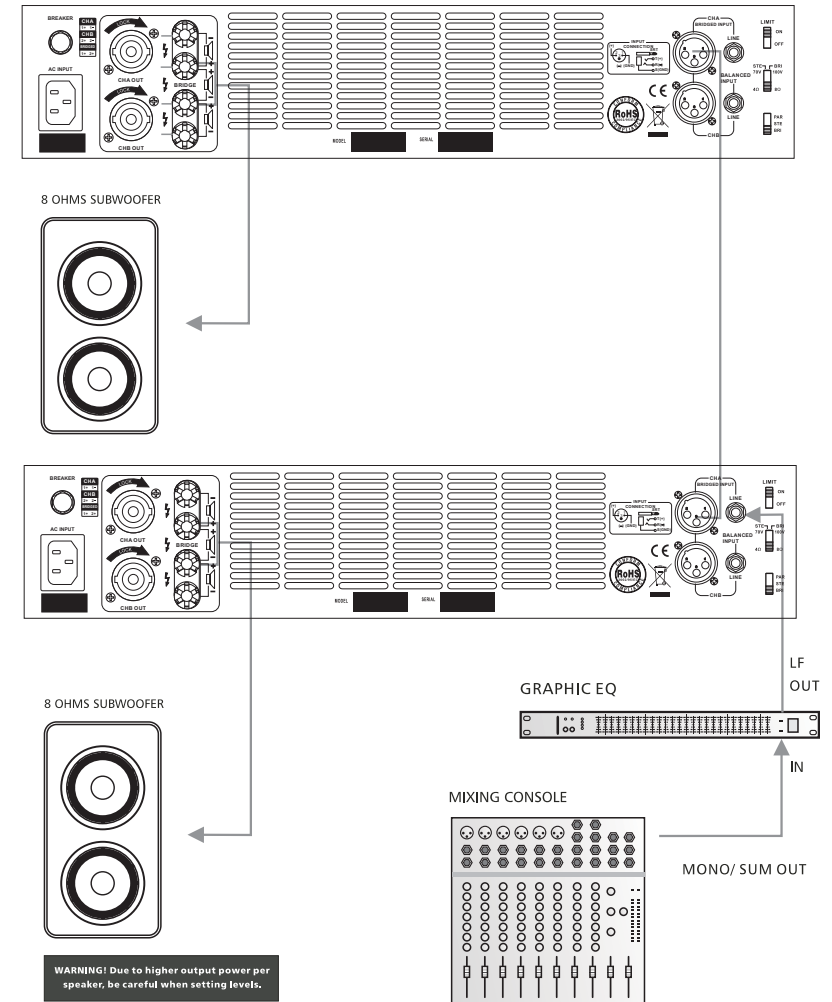



**SWITCH SET TO BRIDGE 100V**

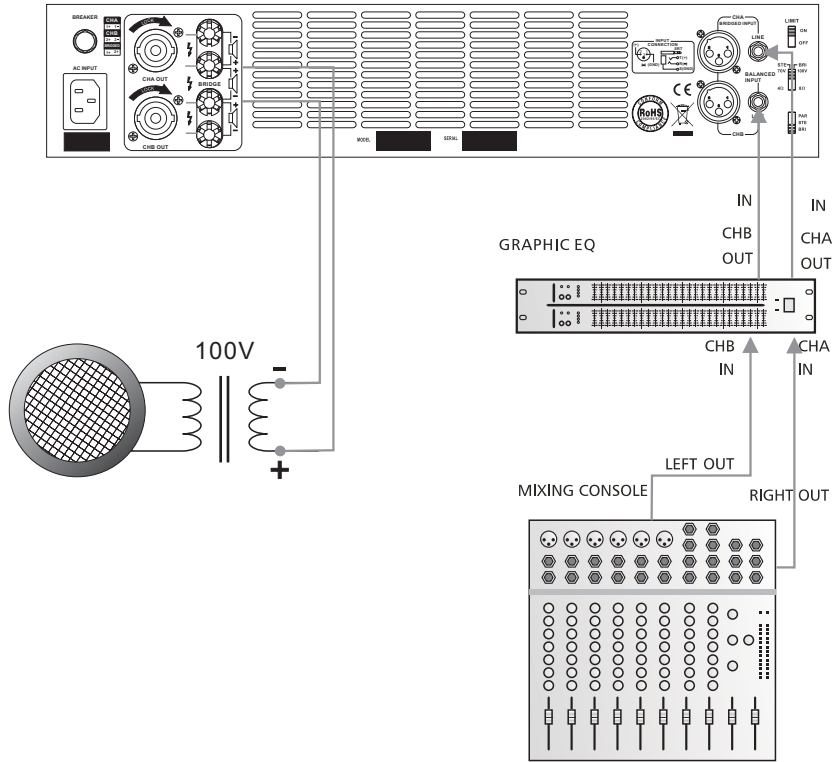

**SWITCH SET TO BRIDGE 70V**

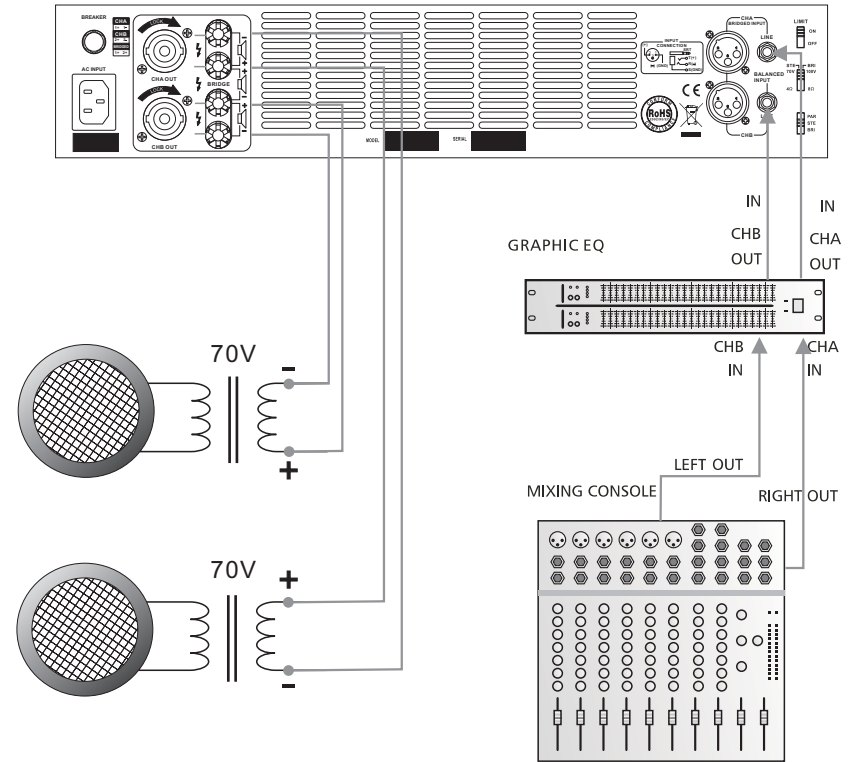

### Parallel Operation

If many speakers must be driven from the same signal, you can operate on PARALLEL way: input from channel A, output the same signal from channel A and B which can drive solely two 8 ohms speakers. The signal smart switch must be set to parallel position.

#### SWITCH SET TO PARALLEL

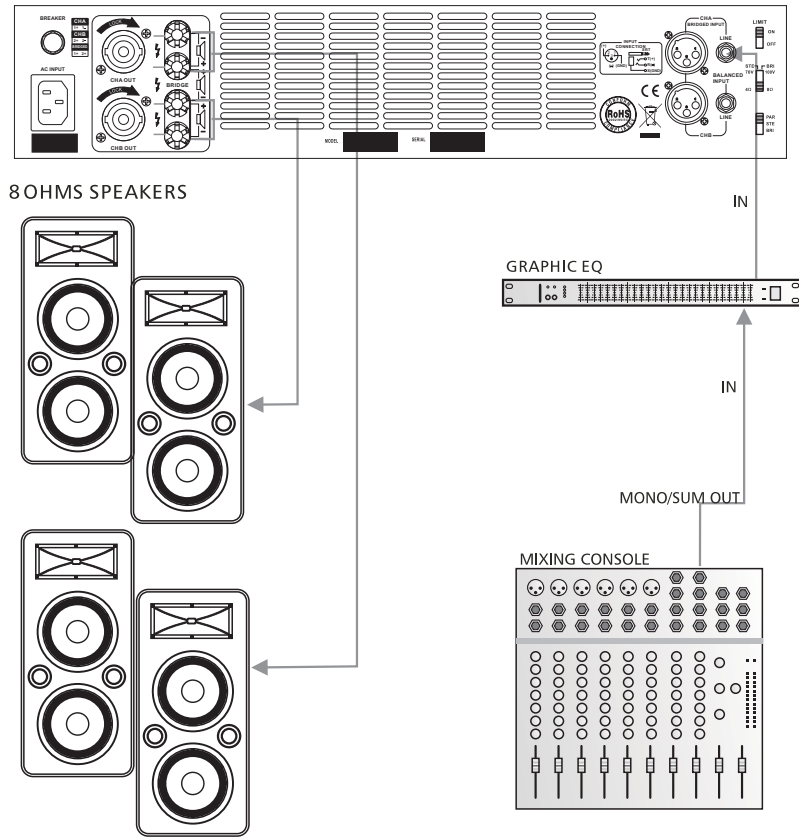

### Mono Bridge Operation

The two internal power amplifiers(CHA and CHB) can be bridged together to form a single, higher powered amp. This is especially useful when using the amplifier to power a subwoofer. In the mono mode, the amplifier uses the channel A input jacks and sensitivity control(channel B's are disabled). When operation in this mode, each channel is independently protected. The signal smart switch must be set to the bridge position and the minimum speaker load impedance must be 8 ohms.

#### SWITCH SET TO BRIDGE

